

This quick start guide provides basic instructions for retrofitting the TM-50/TM-50XL to accept a vision system. Follow these instructions to update the base machine and controller.

Update TM-50 Baseplate

1. Remove Controller
Disconnect all controller cables and remove the **Controller** from the **Controller Baseplate**. Set aside.

2. Remove Controller Baseplate
Using a 5/32" hex wrench, remove the (2) 1/4" BHCS from the top of the **Controller Pedestal**. Set the screws aside.

Remove the **Standoff** from the TM-50 Baseplate. Discard the Standoff.

3. Retrofit Kit Template
Tape the *Retrofit Kit Template* to the back right corner of the **TM-50 Baseplate**. The template shows the location of the (2) Vision Bracket holes which are indicated by two circles with cross-hatch symbols.

If the TM-50 baseplate already has holes at this location, skip Steps 4-5 and proceed to *Step 6: Update Controller*.

If the TM-50 does not have holes at this location, continue with the next step.

4. Mark Hole Locations
Use a *center punch* to mark the hole locations and prepare the spot for drilling. Remove the template and squirt a small amount of lubricant on the hole markings.

5. Drill & Tap Vision Bracket Holes
Using a *21/64 Drill Bit*, drill through the baseplate at the two hole locations. Brush away any metal filings from the drilling process. Using a *10/24 Tap*, create threads in the holes.

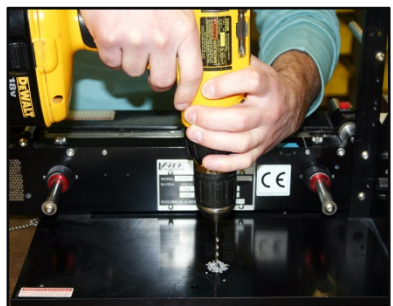
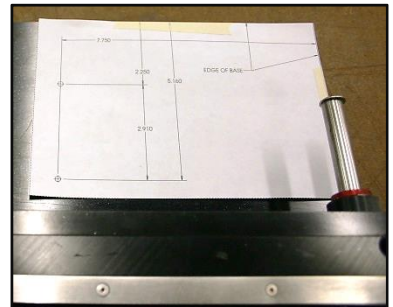
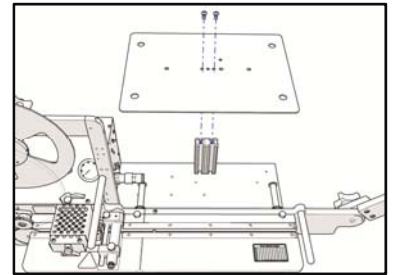
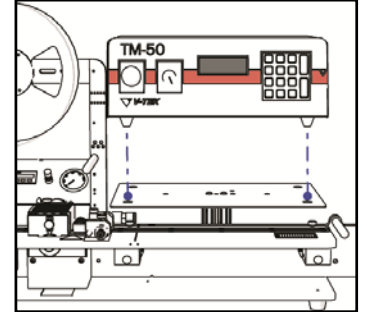

Update Controller

- 1. Check Controller Version**
 Check the back of the controller to determine if it has the Software Option installed.

If the controller has a **Vision Port** the Software Option is already installed. Proceed to the **Keyence IV-G Vision Install Quick Start**.

If no **Vision Port** exists, follow the steps below to update the controller.

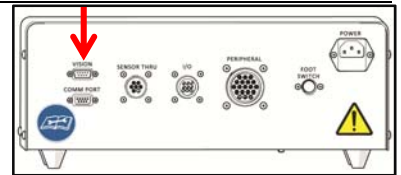

- 2. Remove Controller Cover**
 Using a Phillips head screwdriver, remove the (6) BHCS from the sides of the **Controller Cover**. Remove the Controller Cover and set the cover and screws aside.

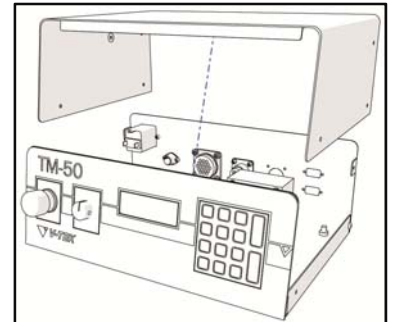

- 3. Install Vision Port**
 Tap out the top left punch-out on the back of the Controller. Insert the **Vision Port** through the new hole in the back of the Controller. Using a 5mm open end wrench, attach the port to the controller with the provided nuts and screws.

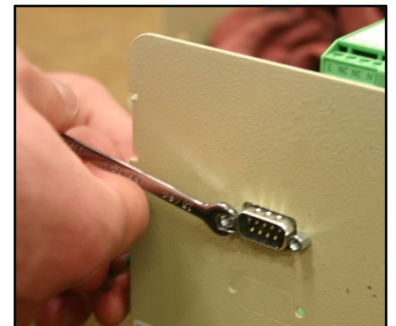

- 4. Connect Vision Plugs**
 Insert Vision Plug **J12** into the J12 connection on the Controller Board.

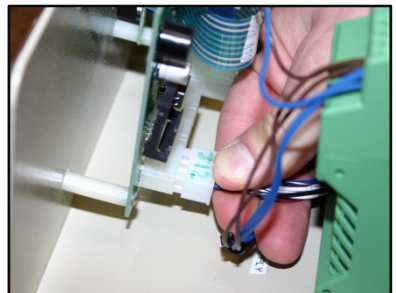

- 5. Remove Software Chip**
 Remove the software chip from the Controller Board Socket.

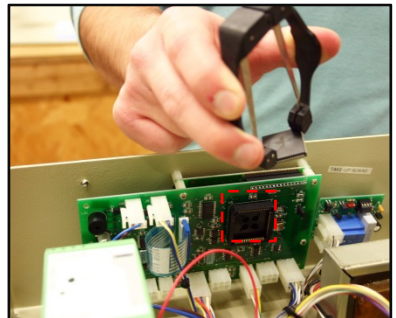

6. Insert New Software Chip
Place the new software chip in the Controller Board, ensuring that the chip label is right-side up and facing out and the dimple is at the top of the chip

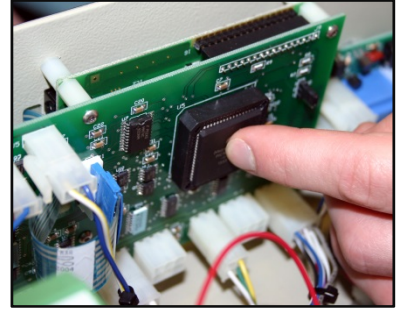

7. Insert Vision Wire in DIN Block
Insert a small screwdriver into **DIN Block 11** as illustrated in the photo on the right. Press the screw driver towards the center of the DIN Block to open that connection. Insert the red Vision Port wire into DIN Block 11.

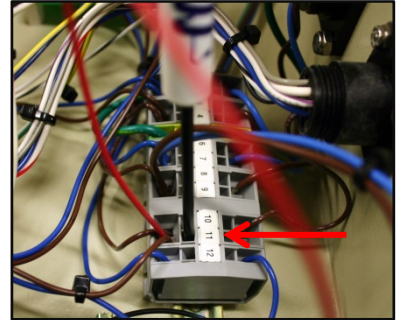

8. Replace Controller Cover
Replace the Controller Cover, replacing and tightening the (6) BHCS.

Proceed to the **Keyence IV-G Vision Install Quick Start** for instructions on installing the Keyence IV-G Vision System.

Once the Vision System is installed see the **Keyence IV-G Monitor Quick Start Guide** OR the **Keyence IV-G Laptop Quick Start Guide** for instructions on HMI and Inspection setup.

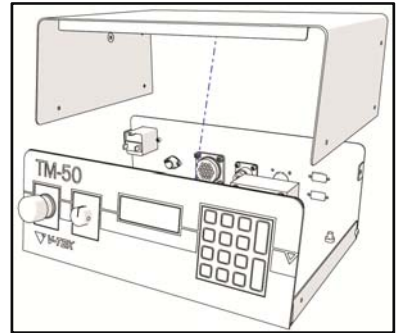

Detailed User's Guides, maintenance instructions and troubleshooting are available on the V-TEK, Inc. website: www.vtekusa.com.

Contact Information

V-TEK, Inc.
751 Summit Ave
Mankato, MN 56001

TEL: (507) 387-2039
website: <http://www.vtekusa.com>
email: service@vtekusa.com



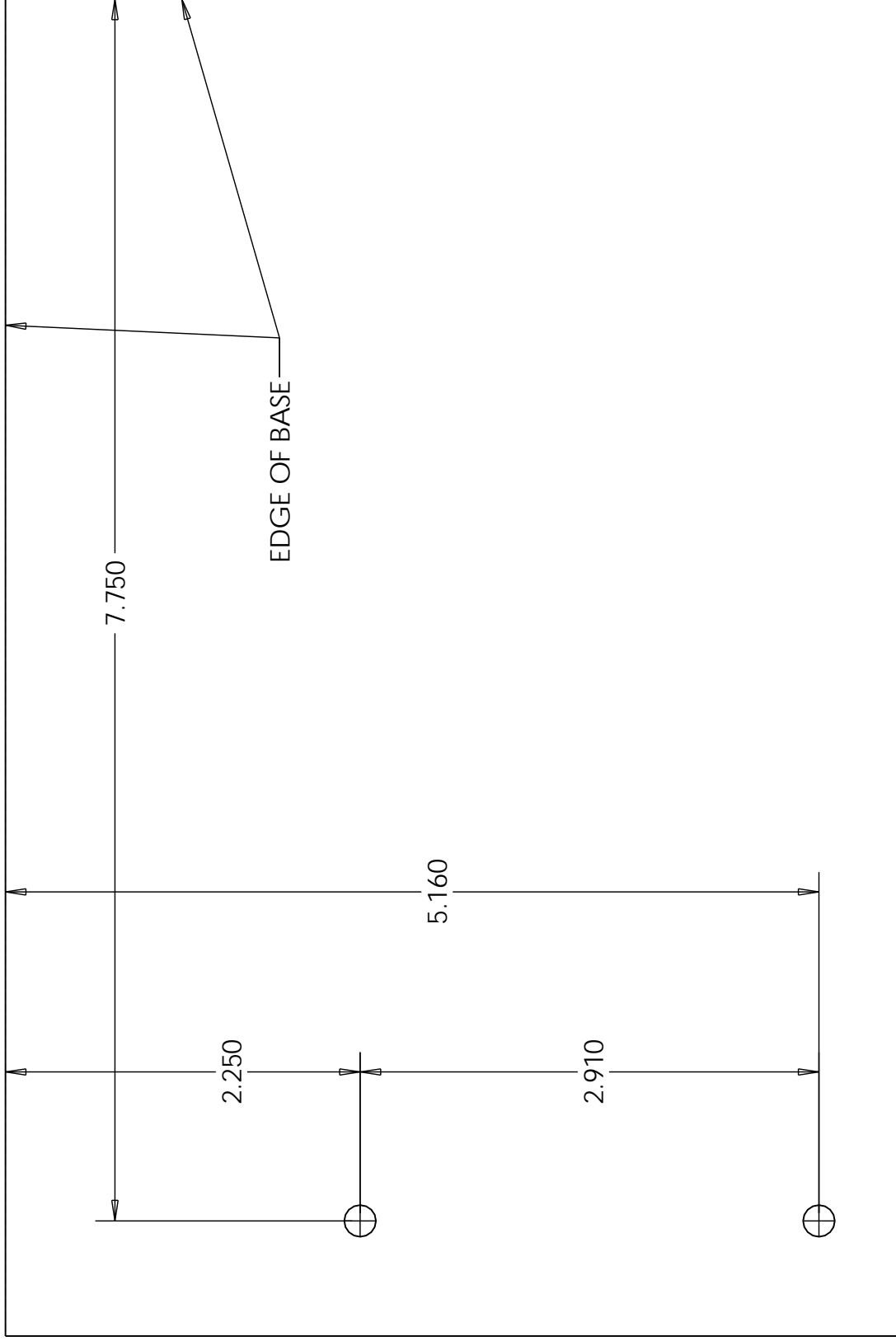

IF CUTTING THREADS
 2X ϕ 0.201 THRU ALL
 1/4-20 UNC THRU ALL

IF CUTTING PASSHOLES
 2X ϕ .266 MINIMUM FOR
 1/4-20 BOLTS

TM-50 VISION RETROFIT HOLE LOCATION TEMPLATE SCALE 1:1